

# TRAC<sub>MAX</sub>





# USER MANUAL

**S200 - D300 - SD500**



## Introduction

Inspired by the principle of “changing the concept of technology in the world,” years of dedicated effort, technical mastery, and field experience were invested to revolutionize the metal detection industry.

The core mission was to develop a product that not only meets the highest international standards of quality and performance, but also establishes Trac Max as a pioneering force in detection technology.

To eliminate the persistent technical errors that have plagued this field for decades, Trac Max was engineered by Geo Ground—Germany’s leading company in geophysical measurement and underground detection systems.

This collaboration ensured that every component, from design to functionality, reflects precision, reliability, and innovation.

The overarching goal was to democratize access to advanced detection technology, making it available to all prospectors—whether seasoned professionals or passionate beginners.

By creating intuitive, easy-to-use systems at a reasonable price, Trac Max empowers individuals across the globe to pursue their golden dreams with confidence and clarity.

With Trac Max, the future of treasure hunting is no longer reserved for the few—it’s a journey open to all.



## Contents

Introduction .....	3
Table of Contents .....	4
Technical Specifications.....	5
Device Components.....	6
Package Contents.....	7
Initial Setup.....	9
Main Unit Overview.....	10
Android App Overview.....	11
Connecting Device to App.....	12
Systems explanation.....	14
Search Mode.....	15
Target Type.....	16
Target and soil type.....	17
Depth-Distance.....	18
Start Scan.....	19
LRL Single Person.....	20
LRL Dual Person.....	24
Advanced Settings.....	27
Trac Max Introduction.....	28
Usage Guidelines.....	29
Warnings.....	30



Specifications		
Package Dimensions	60 × 32 × 11 cm	
Package Weight	13 Kg	
Material	ABS Plastic, Brass	
Processor Type	ESP32 Dual-core Xtensa® 32-bit LX6 microprocessor	
Processor Frequency	Up to 240 MHz	
Main Unit	Screen Type	High Resolution TFT LCD
	Screen Size	1.4 Inch
	Screen Resolution	240 × 240
	Colors	16 million
Power	Battery Type	Lithium-polymer
	Battery Capacity	2000 mAh
	Fast Charging	Yes
	Removable Battery	No
Languages	English- German- French- Italian- Russian- Spanish- Arabic- Persian	
Temperatures	Operation Temperature	0°C – 40°C
	Storage Temperature	–20°C – 60°C
	Humidity	5% – 75%



## Device Components

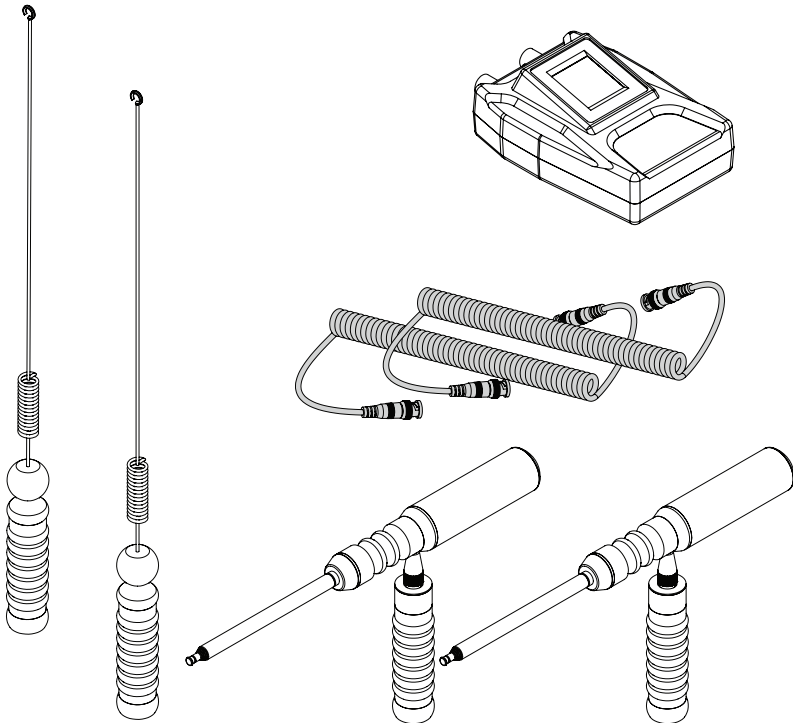



## Package contents

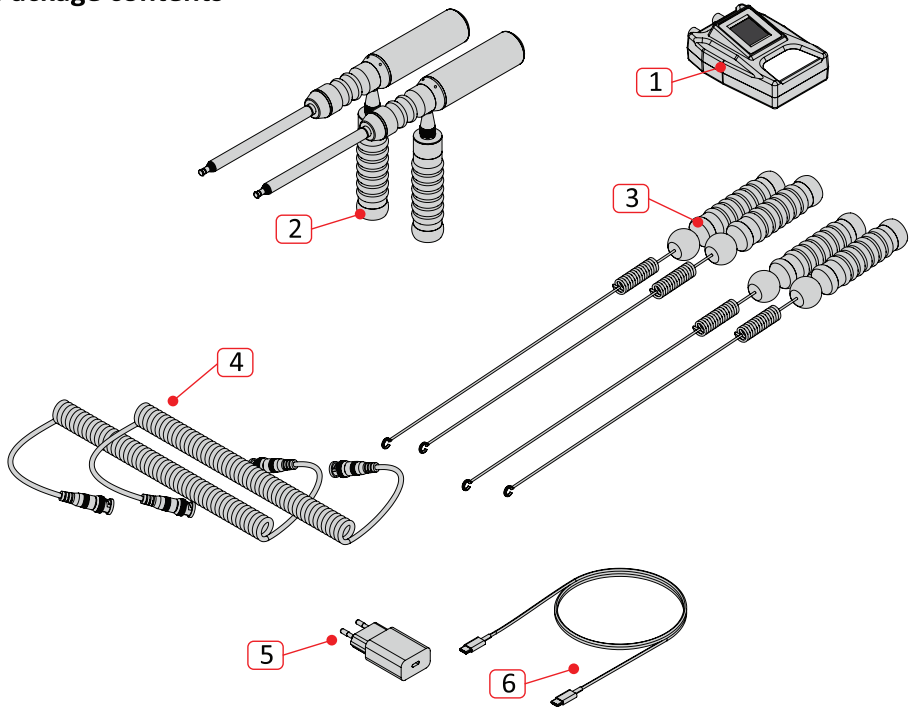



## Package contents

- 1 Main unit
- 2 LRL Rods for single person
- 3 LRL Rods for dual person
- 4 LRL connection cables
- 5 Device charger
- 6 Charge cable
- 7 User Manual



## Initial Setup

Connect the RODS with the LRL device using the specific connection cables.

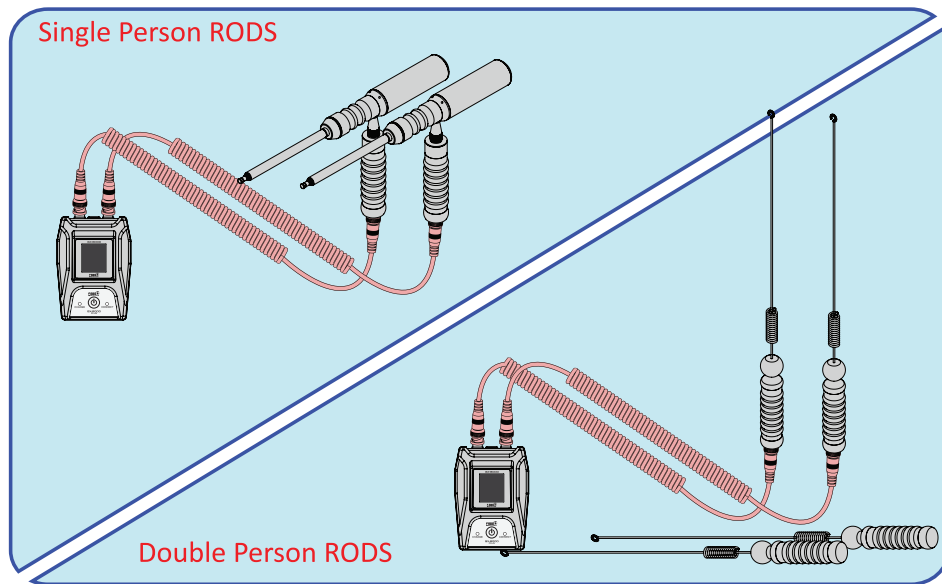

**Note:** use Single person RODS for single mode or double person RODS for dual mode



## Main unit overview

LRL Cable Jack

Charge Jack

Device Screen

Key Pad

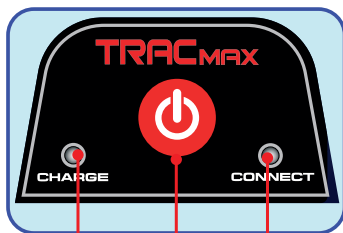

Charge LED

Power Button

Connection LED





## Android application overview

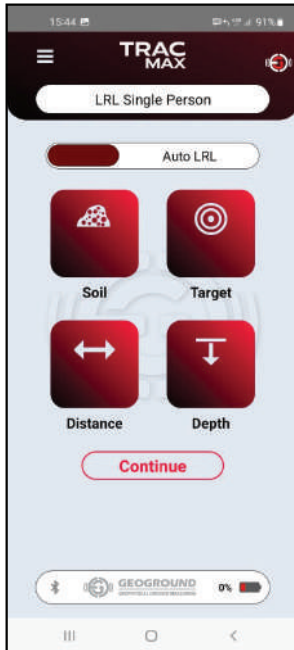

The Trac Max Android application is designed to seamlessly connect your mobile device to the Trac Max hardware, enabling real-time monitoring, configuration, and control. It provides a user-friendly interface with intuitive navigation and customizable settings. Interface available in several languages for global accessibility.

The app can be downloaded from Google Play or installed manually via scanning the QR Code below.

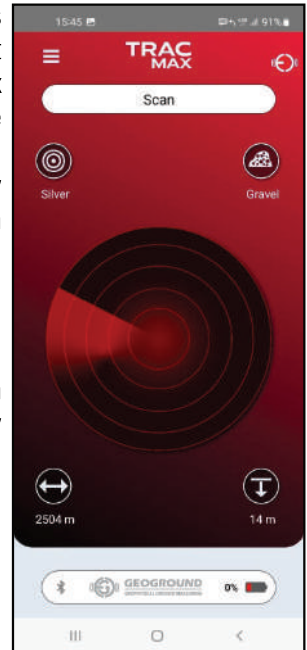



## Connecting Device to App

In the application, tap the menu icon in the top-left corner to open the floating menu.



Navigate to the menu list and tap on 'Settings' to access the settings page.

From the Settings page, select 'Bluetooth' to access its configuration options.

In this view, tap the 'Scan' button to start scanning for nearby available devices.

Tap on the device name and wait until the message changes from 'No device is connected' to 'Connected to TRCMX0000000'.

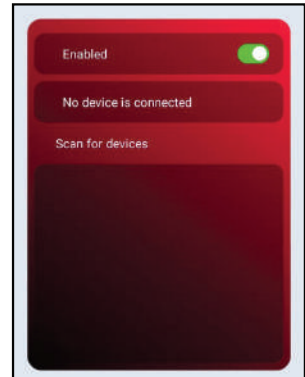
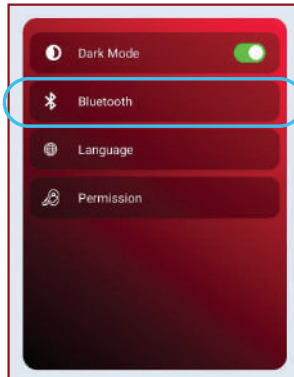



On the device screen, before the connection is established, the status message displays "Disconnected", and the connection icon at the top of the screen shows a disconnected symbol.

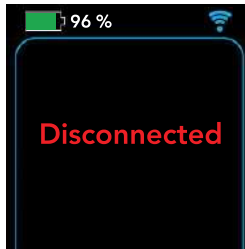

Once the connection is successfully established, the status message changes to "Wait for data", and the connection icon updates to indicate an active connection.

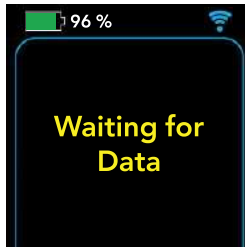



## Systems explanation

Treasure hunting often relies on advanced technology to explore vast terrains. Among the essential tools, long-range locator devices play a key role—designed to detect hidden valuables from a distance using cutting-edge systems.

Let's explore two distinct locator technologies, each suited to different needs in the quest for discovery.

### **1. Single Person Long Range Locator:**

Designed for solo adventurers, the single-person long-range locator is a reliable companion for individuals exploring the unknown.

With its advanced scanning capabilities and precise targeting, this system empowers lone seekers to confidently cover vast territories—offering valuable insights into potential treasure troves and hidden artifacts.

### **2. Double Person Long Range Locator:**

For those who prefer companionship on their quest for riches, the double-person long-range locator offers the perfect solution.

By supporting two users simultaneously, this system encourages collaboration and teamwork—enhancing the overall effectiveness of treasure-hunting expeditions.

With synchronized operation and expanded coverage, partners can explore remote landscapes more efficiently, increasing the chances of uncovering valuable treasures.



## Search Mode

### Search settings configuration:

Once the connection between the Android device and the Trac Max unit is established, in the main menu select either the Single or Dual system mode.

Note: Available system modes depend on the device model:

**Trac Max S200** – Supports Single User mode only

**Trac Max D300** – Supports Dual User mode only

**Trac Max SD500** – Supports both Single and Dual User modes



**LRL Single Person**



**LRL Dual Person**



## Select Target Search Method

On the Search Settings page, choose the target Search Method by tapping the Search Type switch.

There are two available options:

- **Manual LRL:** Requires the user to manually enter the target frequency to initiate the search.

- **Auto LRL:** Allows the user to select a predefined target from the available list.

Each mode offers a different approach depending on the user's preference and search requirements.

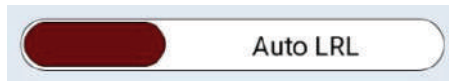

**Auto LRL Mode**



**Manual LRL Mode**



## Target and Soil Type Selection

In the Search Settings, the user can select both the soil type and the target for detection.

In the Soil option, the user can choose a soil type from the available list.

The supported soil types include:

- Low mineral- High mineral - Gravel - Forest - Saline
- Volcanic - Rocky - Wet - Dry - Normal - Sandy

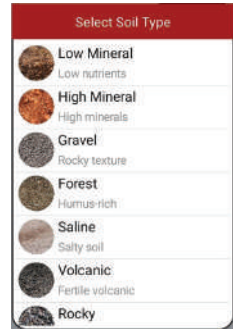

If **Manual LRL Type** is selected, the user must manually enter the target frequency to begin the search.



Tap the Frequency button to open the frequency selector.  
Swipe right or left to browse and choose the desired frequency.  
Once selected, tap OK to confirm and continue.

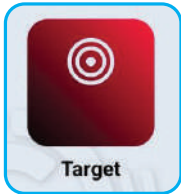

If **Auto LRL Type** is selected, the user can choose a target from the predefined list of available options. Simply select the desired target to proceed with the search.

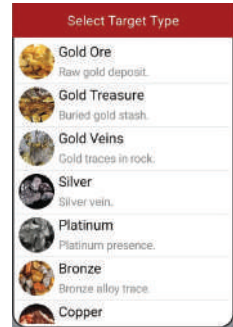

The user can also configure the maximum search depth and the distance to the target by tapping the "**Depth**" and "**Distance**" buttons on the Search Settings page then Swipe right or left to browse and choose the desired values. tap OK to confirm and continue. These parameters help define the scanning target based on the selected soil type and range, enhancing detection accuracy according to the search environment.

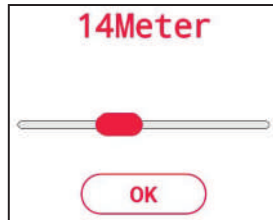

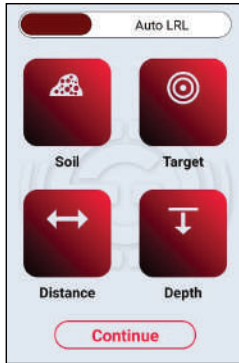

## Starting the Scan

After completing all settings, tap the "**Continue**" button at the bottom of the screen to begin the scanning process. After tapping the "**Continue**" button, the scan page will appear, displaying an animated scanning circle.

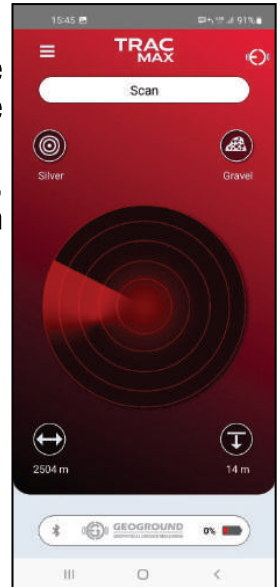

This animation indicates that the system is active and ready to begin scanning the surrounding area. also the user can see the summary of the selected settings on the device screen.



At this stage, the user can proceed with the search based on the selected target and environmental settings.



## How to use LRL single

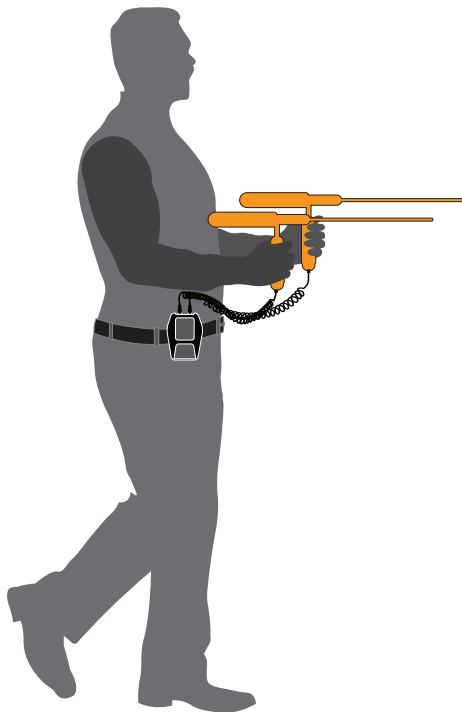

After setting up the search settings and entering the search screen, Connect the LRL device with the specific cables to the RODs and hang the device on your belt.

hold the metal RODs as shown in the figure and start moving. To search in the search area, you can do one of the following two ways:

- 1) Zigzag Path**
- 2) V Shaped Path**

Both of the mentioned methods alone are sufficient for searching, but it is suggested to perform both methods together to be more sure of the correct target during searching.



## 1) Zigzag Search Method

The user must advance in a zigzag pattern, as illustrated in the figure, moving from north to south while observing the rotation direction of the rods (if a target is present).

During this type of search, the user should follow the indicated path. As the search progresses, the rotation of the rods will begin to concentrate around a specific point—this point marks the suspected location of the buried target.

To verify the exact position, it is recommended to repeat the same process from multiple directions toward the initially identified point.

If the same point is consistently confirmed, it can be marked as point (X)—the assumed location of the potential target.

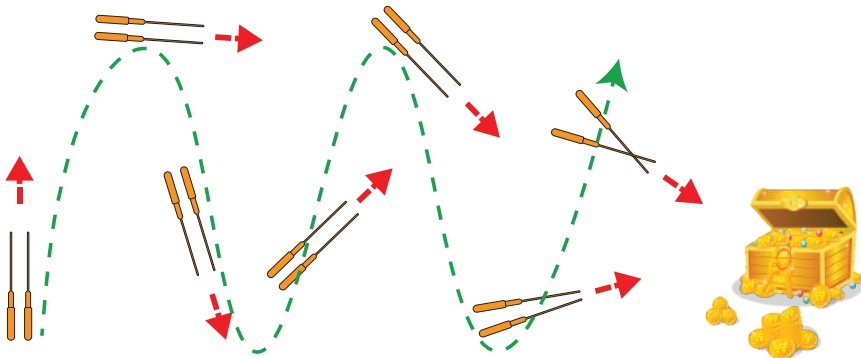



## 2) V Shaped Path

After identifying point (X) as the suspected target location, the user must confirm its validity to ensure the signals are genuine and not false.

To do this, the user should move a few meters north of point (X) to establish a new reference point, point (A).

From point (A), the user should then advance southward, scanning along the right and left sides of point (X)—as illustrated in the figure below.

This method helps verify the concentration of signals and increases confidence in the accuracy of the detected target location.

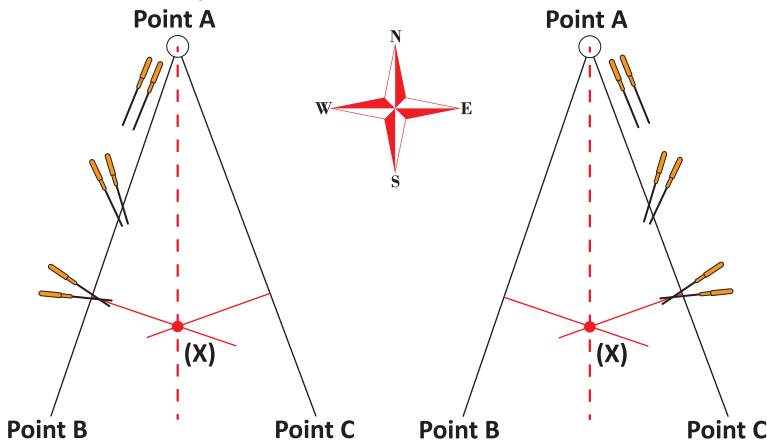



## Confirming the Target Location

While moving from point (A) to point (B), the device will rotate toward point (X) if a target or signal is present.

If the device rotates around its axis and consistently points toward point (X) during this movement, it indicates that point (X) is the confirmed location of the target.

To ensure accuracy, this process should be repeated from two different directions on both sides of point (A), following the specific paths illustrated in the figure below.

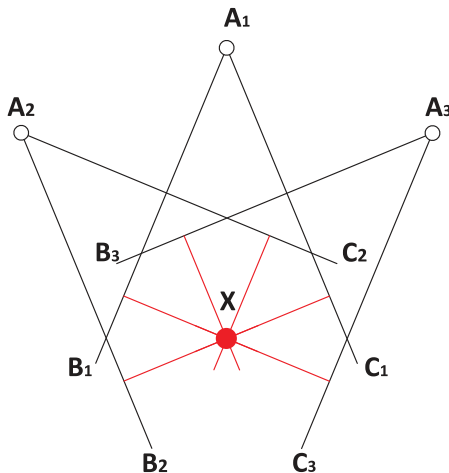



## How to use LRL DUAL

After configuring the search settings and entering the search screen, connect the LRL device to the rods using the designated cables.

Once connected, securely attach the device to your belt to ensure stability and ease of movement during the search process.

Both users must hold the metal rods as illustrated in the figure.

To begin searching within the designated area, follow the procedure outlined below:

Stand at a point in the search area and hold the rods in your hands as shown in the illustration.

Wait for approximately one minute.

Be careful not to pull the rods too tightly, and ensure they are not too loose.

If there is no change in the position or movement of the rods, change your location and repeat the process.

Continue this procedure until the tips of the rods tilt to one side, indicating a possible signal or target direction.

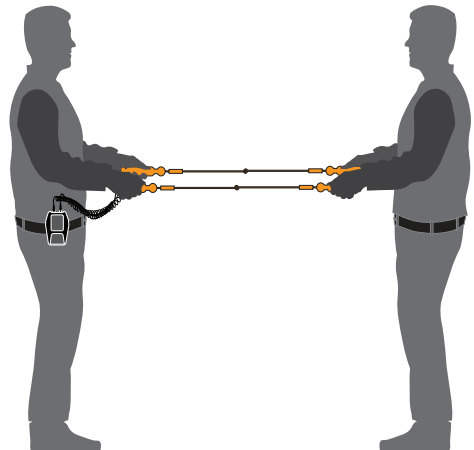



If the rods shift or slip, move a few meters in the direction they indicate and repeat the operation.

Repeat this process several times to observe changes in the direction of the rods.

The different modes indicating changes in the rods are as follows

### 1- The head of the rods tilts to the left:

This indicates that you should move to the left and repeat the operation from the new position.

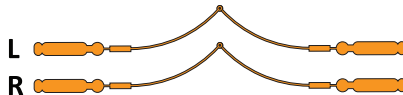

### 2- The head of the rods tilts to the right:

This indicates that you should move to the right and repeat the operation from the new position.

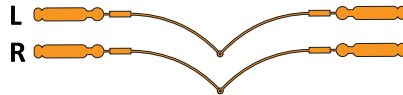

### 3- Both users' rods separate from each other:

This suggests the presence of a void or underground cavity in the area being scanned.

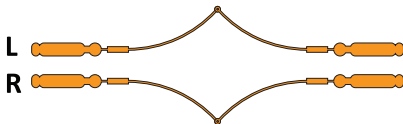



**4- Both users' rods intersect in an X shape or tilt downward:**

This indicates that the selected target is located underground at the point of intersection.

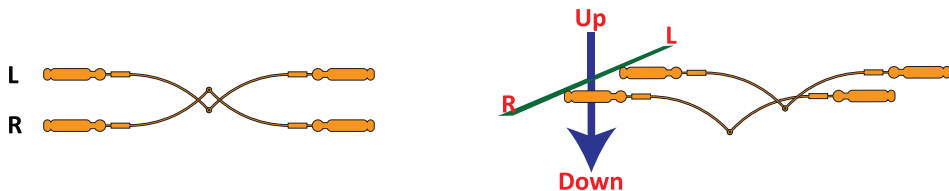

**5- The head of the rods rises:**

This indicates the presence of a target or void behind one of the two users.

In this case, both users should turn 90 degrees and repeat the operation, then observe the results as described in points 1 to 4.

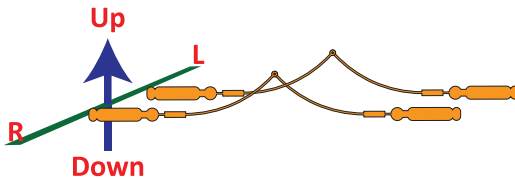



## Accessing Advanced Settings

The user can access advanced settings via the floating menu. By tapping the Settings item, the following options will be displayed:

- **Dark Mode**
- **Bluetooth**
- **Language**
- **Permissions**

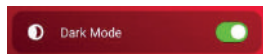
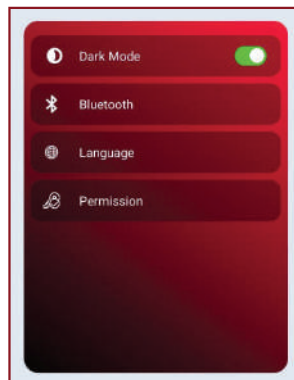

### Dark Mode:

Swipe the switch to enable Dark Mode, which changes the application theme to a darker color scheme.

This mode is ideal for nighttime use, providing a more comfortable viewing experience in low-light environments.

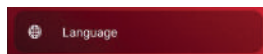

### Language:

In this section, the user can choose their preferred application language from the available list.

Supported languages include:

English- German- French- Italian- Russian- Spanish- Arabic- Persian

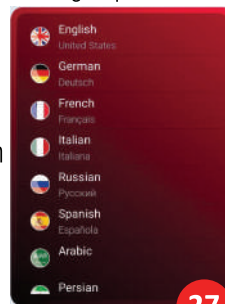



## Trac Max S200,D300,SD500

Trac Max devices—models **S200, D300, and SD500**—are among the most advanced and comprehensive tools for detecting gold and metals.

They are specifically designed for metal detection, treasure hunting, and archaeological excavation, meeting the needs of professional prospectors around the world who seek hidden treasures.

Trac Max is available in three models:

- **S200: Designed for single-user operation**
- **D300: Built for dual-user operation**
- **SD500: Equipped with both single-user and dual-user systems**

Users can select the model that best suits their needs and detection style.

This product line offers all the essential features required by both professionals and beginners, making it suitable for a wide range of metal detection and treasure hunting applications.

Trac Max represents the pinnacle of German engineering, developed by Geo Ground, a leading company in geophysical measurement and underground detection technologies.

Renowned worldwide for its precision and reliability in gold and metal detection, Trac Max delivers powerful performance, accurate results, and dependable equipment—offering the best solutions in the field.

With Trac Max, you can unleash your passion for discovery and confidently explore deeply buried treasures using one of the most reliable and advanced detection systems available today.



## Usage Guidelines & Environmental Notice

To ensure accurate results and avoid false signals, please follow these usage guidelines:

- Do not use the device indoors. Indoor environments often contain multiple metal objects, which may cause continuous false target signals.
- Use the device outdoors, preferably in open fields or areas free from metallic interference.
- Keep other detectors or electromagnetic devices at least 10 meters (30 feet) away from the device during operation.
- Avoid carrying metallic objects while using the device. Items such as keys, mobile phones, or metal components in shoes may be mistakenly detected as targets.

For consumers within the European Union:

Do not dispose of this equipment with general household waste.

The crossed-out wheeled bin symbol on the device indicates that it must be recycled in accordance with local government regulations and environmental standards.

Proper disposal helps prevent environmental harm and supports sustainable resource management.



## WARNINGS

Trac Max S200, D300, SD500 are state-of-the-art electronic devices.

Do not assemble or operate the device before reading the user manual thoroughly. Avoid storing the device or its components in extremely low or high temperatures for extended periods.

- Recommended storage temperature:  $-20^{\circ}\text{C}$  to  $60^{\circ}\text{C}$  (approximately  $4^{\circ}\text{F}$  to  $140^{\circ}\text{F}$ ).
- Do not immerse the device or its components in water. Avoid exposing the equipment to highly humid environments.
- Protect the main unit from physical impacts during normal use.
- For shipping, place the detector securely in its original carton with shock-resistant packaging.
- Disassembly or repair of Trac Max devices is strictly limited to Geo Ground or authorized service centers.
- Any unauthorized disassembly or tampering with internal components will void the warranty.



